

## LCN Compass Rf/Ro Interface



LCN Compass Rf and Ro interfaces implement the Diameter based off-line and on-line billing interfaces specified by 3GPP 32.299. The interfaces are available as C-callable APIs in object file format. Application developers also get a set of call-backs in source code format. Application behaviour can be controlled by customizing these call-backs.

The interfaces, in turn use LCN Compass Diameter base stack to communicate with the remote application.

These interfaces have been developed using Compass ABNF Parser and Code Generator. This

allows LCN to quickly support new releases of standards.

### Product Perspective

The following diagram shows the supported interfaces.

Figure 1 Billing Interfaces

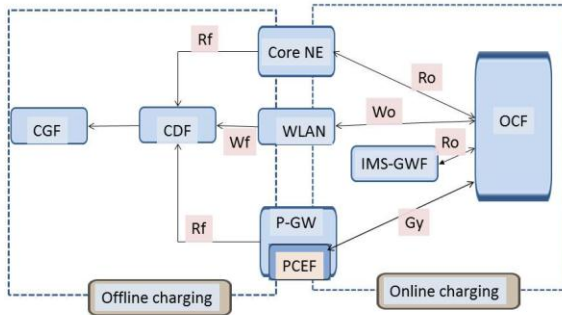

## Product Description

The following diagram shows the Rf/Ro interfaces in context.

The client-side interfaces are available to equipment vendors to develop the functionality to report billing information to the Charging Data Function (CDF) as described in 3GPP 32.299. Server side APIs can be used by BSS vendors to develop CDF functionality, to receive the Diameter accounting messages and process them. The interfaces, along with lower layers, hide all protocol details.

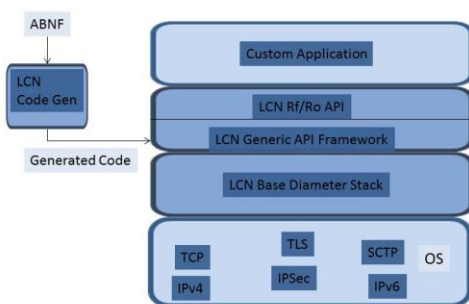

Figure 2 Rf/Ro Interfaces - The Context

## Product Features

- C-callable APIs, hiding protocol details and complexity
- Customizable call-back mechanism
- Server and client side implementation
- Thread safety for scalable application development
- Professional services for any customization of your special requirements

## Advantages

Compass family of products offers standard interfaces as building blocks to OEMs building 3GPP functional elements. These interfaces are available as simple C-callable APIs. These have been built over LCN's standard compliant diameter implementation. With these APIs, OEMs can focus on building their core functionality. Advantages are,

- Reduced complexity of the development project
- Reduced time-to-market
- Considerable cost savings
- Reduced interoperability issues with other products
- Reduced integration efforts

## **Specifications and Standards Compliance**

*RFC 3588, Diameter Base Protocol*

*RFC 3539, AAA Transport Profile*

*RFC 4006, Diameter Credit Control Application*

*3GPP TS 32.299 Rel 9, Diameter Charging Applications*

*Transport : TCP and SCTP*

*Protocol: IPv4 and IPv6*

## **Contact**

Please write to us at [info@lcnpl.com](mailto:info@lcnpl.com) for more information.

Our URL: <http://www.lcnpl.com>